

Two-doors refrigerator-freezer

Instructions for installation and use

TA 5 - TA 5 S

 **INDESIT**



GB **Two-doors refrigerator-freezer**
Instructions for installation and use



To maintain the EFFICIENCY and SAFETY of this appliance, we recommend:

- call only the Service Centers authorized by the manufacturer
- always use original Spare Parts

Safety - a good habit to get into.

ATTENTION

Read your manual carefully since it contains instructions which will ensure safe installation, use and maintenance of your appliance.

Your Refrigerator is built to International safety standards (EN60) and has been awarded the European approval mark (IMQ) for compliance with UK electrical safety requirements. It also meets the EC standards on the prevention and elimination of radio interference (EC directive 87/308 - 02.06.89).

1. This appliance is designed to be used indoors and under no circumstances should it be installed outside even if protected by a roof. Leaving the appliance exposed to the rain and whether is exceedingly dangerous.
2. The appliance should be used only by adults and exclusively for storing foodstuffs in compliance with the instructions provided in this manual. Under no circumstances should children be allowed to operate, or tamper with, this product.
3. Do not attempt to operate or handle this appliance when barefoot, or with wet hands or feet.
4. It is highly recommended that you do not operate this appliance by connecting it to the power supply with extensions or multiple socket plugs. If the refrigerator has been installed between two cabinets, make sure that the supply chord is not dangerously crimped or trapped beneath a heavy object.
5. Never pull the cable or the appliance to remove the plug

from the socket; this is exceedingly dangerous.

6. Do not touch the internal cooling elements, especially if your hands are wet, since you could burn or hurt yourself.
7. Before doing any cleaning, disconnect the appliance from the electricity (by pulling out the plug or turning off the general switch in your home); it is not sufficient to place the temperature regulation knob on ● to cut off the power.
8. Before disposing of your old appliance, remember to break or remove the lock as a safety measure to protect children who might lock themselves inside the appliance when playing. In addition, if the appliance is a new one with a lock, keep the key out of the reach of small children.
9. If your appliance is not operating properly, read the chapter entitled, "Trouble Shooting", which might help you resolve the problem, before calling an after-sales service centre. Do not attempt to repair the appliance by tampering with the internal components.
10. If the power supply cord must be replaced, please contact one of our Customer Service Centers. In some cases, the connections are made using special terminals and in others a special tool must be used to access the connections.
11. Do not use electric appliances inside the compartment for food storage, if these are not those recommended by the manufacturer.
12. At the end of the functional life of your appliance – containing cyclopentane gas in the insulation foam and perhaps gas R600a (isobutane) in the refrigeration circuit – the latter should be made safe before being sent to the dump. For this operation, please contact your dealer or the Local Organisation in charge of waste disposal.

Installation

Proper installation of the appliance is essential to ensure the best and most efficient performance of your appliance.

Ventilation

The compressor and condenser generate heat and, therefore, need to be ventilated properly. Rooms with less than perfect ventilation are not very suited for installation of the appliance. Therefore, it should be installed in a room with an opening (window or French window) that provide the appropriate amount of air re-circulation. It is also important that the room not be too humid.

During installation, make sure not to cover or obstruct the grates that allow for proper ventilation of the appliance.

For proper ventilation of the appliance, you must leave:

- a space of at least 10 cm between the top part and any cabinets above it;
- a space of at least 5 cm between the sides of the appliance and any adjacent cabinets/walls.

Away from Heat

Avoid positioning the appliance in a place where it is directly exposed to sunlight or near an oven, cook top or the like.

Levelling

The floor should be perfectly level; if not, you can adjust the feet at the front of the appliance.

Earthing

Before making the electrical connection, check that the voltage shown on the data plate, that you will find on the bottom left hand side of the appliance next to the crisper, corresponds to that of your home and that the socket is earthed in compliance with all current electrical regulations. If the system is not earthed, the manufacturer declines all liability for consequent damages or losses. Do not use adapters or multiple sockets. **Position the appliance in such a way that you can access the socket where it is plugged in.**

Check the power load

The electrical socket must support the maximum power load of the appliance shown on the data plate (on the bottom left hand side of the appliance next to the crisper).

Before plugging the appliance to the mains

Stand the appliance upright and wait at least 3 hours before plugging the appliance into the mains to ensure proper performance.

Electrical connection

Your appliance is now supplied with a 13 amp fused plug that can be plugged into a 13 amp socket for immediate use. Before using the appliance please read the instructions below.

WARNING - THIS APPLIANCE MUST BE EARTHED. THE FOLLOWING OPERATIONS SHOULD BE CARRIED OUT BY A QUALIFIED ELECTRICIAN.

Replacing the fuse:

When replacing a faulty fuse, a 13 amp ASTA approved fuse to BS 1362 should always be used, and the fuse cover re-fitted. If the fuse cover is lost, the plug must not be used until a replacement is obtained.

Replacement fuse covers:

If a replacement fuse cover is fitted, it must be of the correct colour as indicated by the coloured marking or the colour that is embossed in words on the base of the plug. Replacements can be obtained directly from your nearest Service Depot.

Removing the plug:

If your appliance has a non-rewireable moulded plug and you should wish to remove it to add a cable extension or to re-route the mains cable through partitions, units etc., please ensure that either:

- the plug is replaced by a fused 13 amp re-wireable plug bearing the BSI mark of approval
- or:
- the mains cable is wired directly into a 13 amp cable outlet, controlled by a switch, (in compliance with BS 5733) which is accessible without moving the appliance.

Disposing of the plug:

Ensure that before disposing of the plug itself, you make the pins unusable so that it cannot be accidentally inserted into a socket. **Instructions for connecting cable to an alternative plug:**

Important: the wires in the mains lead are coloured in accordance with the following code:

Green & Yellow	- Earth
Blue	- Neutral
Brown	- Live

As the colours of the wires in the mains lead may not correspond with the coloured markings identifying the terminals in your plug, proceed as follows:

Connect Green & Yellow wire to terminal marked "E" or  or coloured Green or Green & Yellow.

Connect Brown wire to terminal marked "L" or coloured Red.

Connect Blue wire to terminal marked "N" or coloured Black. If a 13 amp plug (BS 1363) is used it must be fitted with a 13 amp fuse. A 15 amp plug must be protected by a 15 amp fuse, either in the plug or adaptor or at the distribution board. If you are in any doubt about the electrical supply to your machine, consult a qualified electrician before use.

How to connect an alternative plug:

The wires in this mains lead are coloured in accordance with the following code:

BLUE	"NEUTRAL" ("N")
BROWN	"LIVE" ("L")
GREEN AND YELLOW	"EARTH" ("E")

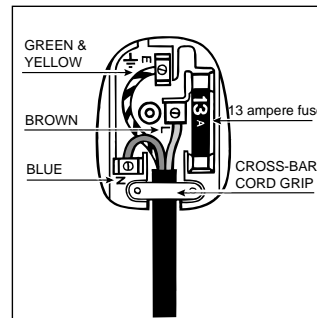

Disposing of the appliance:

When disposing of the appliance please remove the plug by cutting the mains cable as close as possible to the plug body and dispose of it as described above.

A closer look

A Thermostat knob for regulating the temperature

Use this knob to regulate the temperature of the refrigerator. The following settings are available:

- The refrigerator is off;
- 1 less cold;
- 7 colder

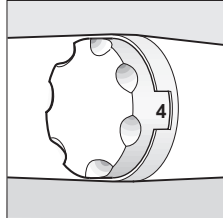

G Adjustable feet

H Fruit and vegetable drawer

I Removable height adjustable shelves

J Compartment for storing frozen foods, freezing fresh foods and making ice

B Ice tray

C Removable shelf with lid and egg compartment

D Beverage can shelves

E Removable miscellaneous shelf

F Removable door shelf for bottles

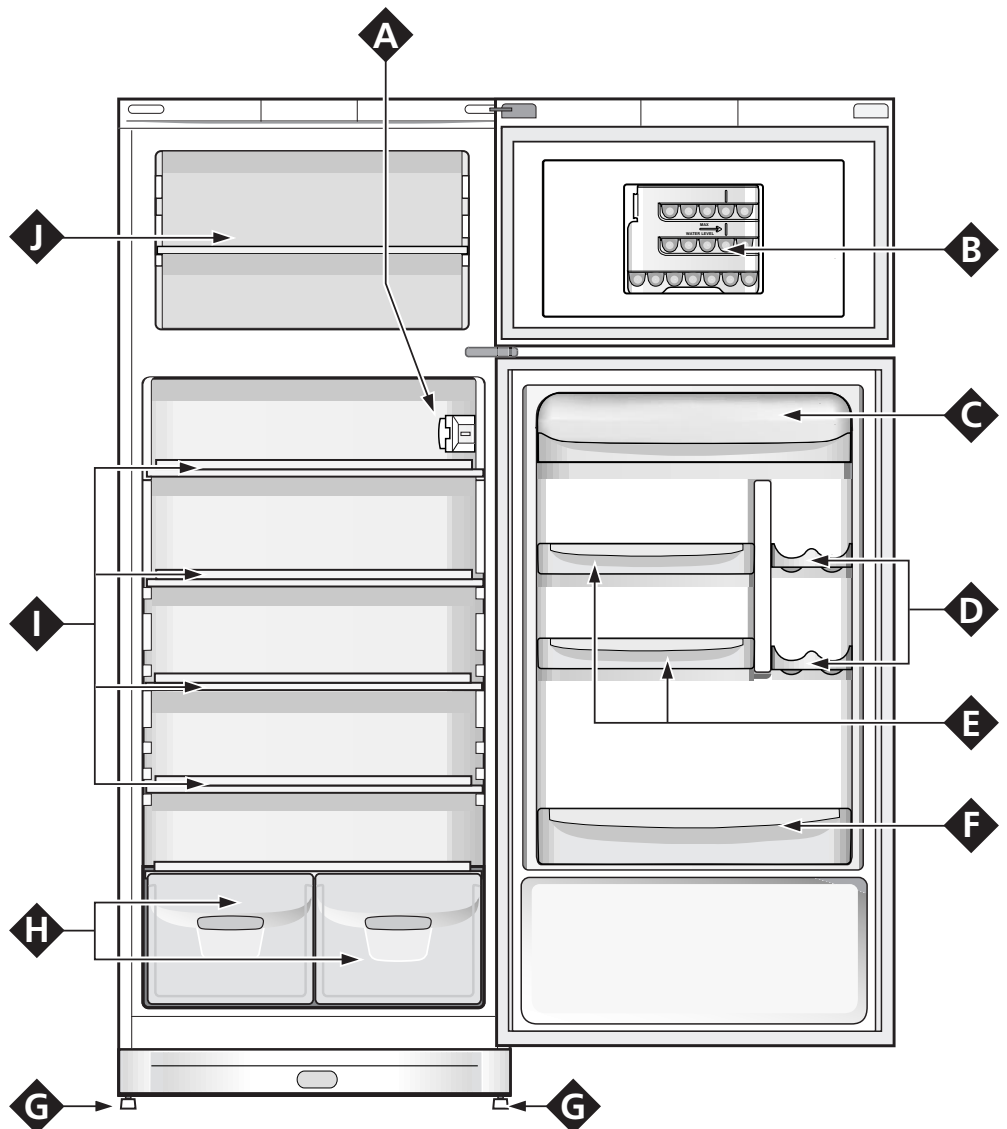

How to Start the Appliance

NOTICE

After the appliance has been delivered, stand it in the upright position and wait approximately 3 hours before connecting it to the electrical outlet to guarantee that it operates properly.

Before placing foodstuffs in the refrigerator or freezer, clean the interior well with warm water and baking soda.

After putting the plug in the socket, make sure that the light is on inside the appliance and then turn the thermostat knob (A) to the "4" setting. After a few hours have passed, you can place fresh food in the refrigerator compartment and frozen foods into the freezer.

How to use the refrigerator compartment...

The thermostat automatically regulates the temperature inside the appliance

1 = less cold

7 = colder

It is recommended that a medium setting be used.

To increase the amount of space, optimize arrangement and improve appearance, this appliance has a "cooling area" located within the back panel of the refrigerator compartment. When the appliance is operating, this panel may be covered with frost or droplets of water depending on

whether the compressor is operating or not at a given time. Do not be concerned about this! The refrigerator is operating normally.

If the thermostat knob is positioned on higher settings while the refrigerator is heavily filled and the ambient temperature high, the appliance may run continuously, resulting in the formation of frost on the back cooling area. This will lead to an increase in energy consumption.

To avoid this situation, just turn the thermostat knob to a lower setting so that the appliance defrosts automatically.

Storing Food in the Refrigerator Compartment

Food	Storage Time	Location in the Refrigerator
Wrapped meat and cleaned fish (use plastic wrap or pack in plastic bags)	2 or 3 days	On the shelf above the vegetable crisper (which is the coldest area).
Fresh cheese	3 or 4 days	On the shelf above the vegetable crisper (which is the coldest area).
Eggs	1 month	In special egg rack on door.
Butter, margarine		On any shelf.
Cooked or precooked food (place in air-tight containers and when cool store in refrigerator)	3 or 4 days	On any shelf.
Sausages, salami, sandwich meats in general, fresh pasta, custards, puddings, chocolates, cream pastries, bread, dry pastries, red tomatoes	3 or 4 days	On any shelf.
Bottled products, milk, drinks, yoghurt		On special door shelves.
Fruits and legumes		In vegetable crisper.

What Not to Store in the Refrigerator

Garlic (transmits odour), onions and leeks. Bananas (they will turn black). Citrus fruits. Potatoes and root vegetables (store in dark, dry places).

- Within the refrigerator compartment, the air circulates naturally, with the colder air falling because it is heavier. This is the reason why meat and cheeses should be placed above the vegetable crisper.

- Please follow our instructions carefully on maximum storage time: any food, even the freshest, will not remain edible for any extended amount of time.

- Contrary to popular belief, cooked foods do not store any longer than raw food.

- Do not place liquids in containers without covering them because this will lead to an increase in the level of moisture within the refrigerator, causing the formation of frost.

- Remember to cool hot food before storing otherwise the temperature inside the appliance will increase, causing the compressor to work harder and use more energy.

- Be careful not to place containers (plastic or glass), food or other objects in direct contact with the cooling area of the back wall of the refrigerator. This could harm the food, increase energy consumption and facilitate the formation of condensate (on food, containers, etc.).

- The refrigerator compartment is equipped with convenient, removable shelves (Fig. 1) which can be adjusted for height using the shelf guides. This allows you to place even large containers and foodstuffs in the refrigerator.

Beverage can shelves

The can rack (Fig. 2) on the inner door allows you to store not only cans, but also yoghurt, butter and other containers, according to your requirements.

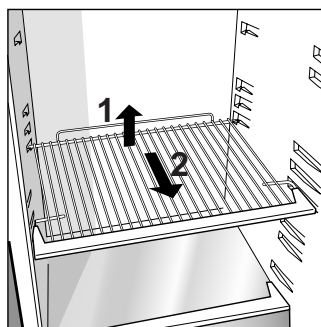

Fig. 1

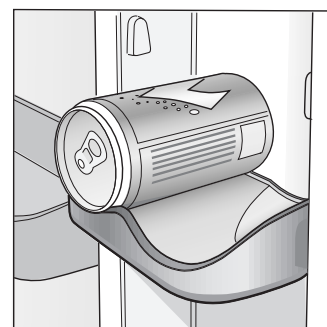

Fig. 2

Freezing Foods Properly

- For the preparation of food to be frozen, please consult a specialized manual.

- Food that has been thawed, even partially, must not be re-frozen: you must cook it in order to consume it (within 24 hours) or to freeze it once again.

- Fresh foods that you intend to freeze must not be placed in contact with those that are already frozen or those that have been fast-frozen. Rather, they must be placed atop the grate in the freezer compartment, in contact with the walls of the compartment (back or side) if possible. Please keep in mind that proper conservation of frozen foods depends on the speed with which they are frozen.

- During the freezing process, avoid opening the door of the freezer.

- The maximum daily quantity of food that can be frozen is indicated on the rating plate located to the left of the vegetable crisper.

- In order to freeze and then thaw foods optimally, it is recommended that you divide food into small portions so that they freeze quickly and uniformly. The packages should be clearly marked with the content and the date they were frozen.

- Do not open the freezer door in the event of a power failure or malfunction. This precaution will slow the rise in temperature within the compartment. If the door is not opened, frozen and fast-frozen foods will remain in their current state for approximately 9-14 hours.

- Do not place full bottles in the freezer: they could easily burst because all liquids increase in volume when they freeze.

- If the ambient temperature remains below 14°C for an extended period of time, the temperature needed for extended storage of food in the freezer will not be reached, resulting in reduced storage life of the food.

Ice tray

This new concept of ice tray is an exclusive Merloni patent. The fact that they are situated on the inner door of the freezer compartment ensures greater ergonomics and cleanliness: the ice no longer comes into contact with the food placed inside the freezer compartment; furthermore, the dripping of the water during filling is avoided (a lid to cover up the hole after filling with water is also provided).

To remove the ice trays from their housings, push the tray upwards and then pull it out (fig. 3). To put the tray back in place, insert the top part into the special housing and, once in a vertical position, just let it drop into place.

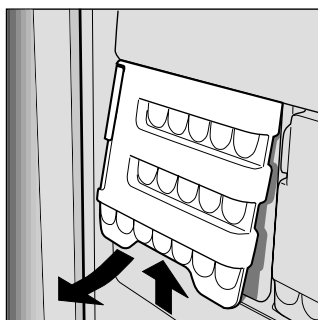

Fig. 3

Instructions for use (Fig. 4)

Fill up the tray with water via the special hole up to the level indicated (MAX WATER LEVEL), taking care not to exceed it: inserting more water than is necessary will lead to the formation of ice which could obstruct the exit of the ice cubes.

If you have used an excessive amount of water, you will have to wait until the ice has melted, empty out the tray and re-fill it with water.

Once you have filled the ice tray up with water through the hole indicated, turn it by 90°. Thanks to the connected compartments, the water fills up the special shapes, after which you can cover the hole up with the special cap and place the ice tray in the inner door of the freezer compartment.

Once the ice has formed, all you need to do is to knock the tray against a hard surface so that the ice cubes come away from their housing and come out of the same hole used to fill the tray with water. To make it easier for the ice cubes to come out, wet the outside of the tray.

WARNING: every time you fill up the ice tray with water, make sure that the same is completely empty and that there are no traces of ice left inside it.

The minimum time required for ice to form well is approximately 8 hours.

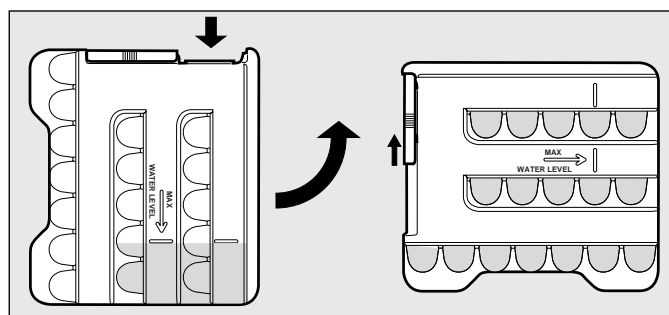

Fig. 4

Tips on Saving Energy

- Install the Appliance Properly

In other words, away from sources of heat and direct sunlight, in a well ventilated room complying with the minimum distances indicated in the paragraph entitled, "Installation/Ventilation."

- Use the Right Temperature Setting

A setting which is too cold increases energy consumption.

- Do not Overfill

To conserve food properly, the cold air must circulate freely within the refrigerator. If it is overfilled, this will prevent proper air circulation, forcing the compressor to work continuously.

- Close the Doors

Open your refrigerator as little as possible because each time you do so you lose much of the cold air. To raise the temperature to the proper level again, the motor must work for a long time, consuming energy.

- Keep an Eye on the Seals

Keep the seals clean and make sure that they adhere well to the door. This alone will ensure that no cold air escapes.

- No Hot Foods

A hot pot or pan placed in the refrigerator immediately raises the temperature several degrees. Let hot cookware and food cool to ambient temperature before placing them in the refrigerator.

- Defrost the Freezer

Check the thickness of the frost on the walls of the freezer and immediately defrost it if the layer of frost is too thick. (see the section entitled, "Keeping your Appliance in Shape").

Guide to Using the Freezer

Food	Wrapping	Tenderising (days)	Storage (months)	Thawing Time
Beef Roast	Tinfoil	2 / 3	9 / 10	Not required.
Lamb	Tinfoil	1 / 2	6	Not required.
Pork Roast	Tinfoil	1	6	Not required.
Veal Roast	Tinfoil	1	8	Not required.
Veal/Pork Chops	Each piece wrapped in cling wrap and then in tinfoil (4 to 6 slices)		6	Not required.
Veal/Lamb Cutlets	Each piece wrapped in cling wrap and then in tinfoil (4 to 6 slices)		6	Not required.
Minced Meat	In aluminium containers covered with cling wrap.	Freshly minced	2	Slowly in refrigerator.
Heart and Liver	Plastic Baggies		3	Not required.
Sausages	Cling Wrap or Tinfoil		2	As necessary.
Chicken and Turkey	Tinfoil	1 / 3	9	Very slowly in refrigerator.
Duck and Goose	Tinfoil	1 / 4	6	Very slowly in refrigerator.
Pheasant, Partridge and Wild Duck	Tinfoil	1 / 3	9	Very slowly in refrigerator.
Hare and Rabbit	Tinfoil	3 / 4	6	Very slowly in refrigerator.
Venison	Tinfoil or Cling Wrap	5 / 6	9	Very slowly in refrigerator.
Large Fish	Tinfoil or Cling Wrap		4 / 6	Very slowly in refrigerator.
Small Fish	Plastic Baggies		2 / 3	Not required.
Crustaceans	Plastic Baggies		3 / 6	Not required.
Shellfish	Store in salted water in aluminium containers or plastic containers.		3	Very slowly in refrigerator.
Boiled Fish	Tinfoil or Cling Wrap		12	In hot water.
Fried Fish	Plastic Baggies		4 / 6	Directly in pan.

Fruits and Vegetables

Food	Preparation	Blanching Time	Wrapping	Storage (months)	Thawing Time
Apples and Pears	Peel and cut into slices.	2'	In Containers (cover with syrup)	12	In refrigerator very slowly.
Apricots, Peaches, Cherries and Plums	Peel and pit.	1' / 2'	In Containers (cover with syrup)	12	In refrigerator very slowly.
Strawberries Blackberries and Raspberries	Rinse and fry.		In Containers (cover with sugar)	10 / 12	In refrigerator very slowly.
Cooked Fruit	Cut, cook and strain.		In Containers (add 10% sugar)	12	In refrigerator very slowly.
Fruit Juice	Wash, cut and crush.		In Containers (sugar to taste)	10 / 12	In refrigerator very slowly.
Cauliflower	Remove leaves, cut head into small pieces and blanch in water and a little lemon juice.	2'	Plastic Baggies	12	Not required.
Cabbage and Brussel Sprouts	Wash and cut into small pieces.	1' / 2'	Plastic Baggies	10 / 12	At room temperature.
Peas	Shell and wash.	2'	Plastic Baggies	12	Not required.
French Beans	Wash and slice if required.	2	Plastic Baggies	10 / 12	Not required.
Carrots, Peppers and Turnips	Peel, wash and slice if necessary.	3' / 4'	Plastic Baggies	12	Not required.
Mushrooms and Asparagus	Wash, peel and cut up.	3' / 4'	Plastic Baggies or Containers	6	At room temperature.
Spinach	Wash and mince.	2'	Plastic Baggies	12	At room temperature.
Vegetable for Soups	Wash and cut up in small pieces.	3'	Plastic Baggies or Containers	6 / 7	Not required.
Various Foods	Preparation	Blanching Time	Wrapping	Storage (months)	Thawing time
Bread			Plastic Baggies	4	At room temperature and in the oven.
Cakes			Plastic Baggies	6	About 10 minutes at room temperature, cook at 100/200°C.
Cream			Plastic Containers	6	At room temperature or in refrigerator.
Butter			In original wrapping or tinfoil	6	In refrigerator.
Boiled Food or Vegetable Soup			Plastic or Glass Containers	3 / 6	At room temperature or in hot water.
Eggs			Freeze without shells in small containers	10	At room temperature or in refrigerator.

Keeping Your Appliance in Shape

Defrosting

WARNING: do not damage the refrigeration circuit. Do not use mechanical devices or other tools to speed up the defrosting process, unless they have been recommended by the manufacturer.

How to Defrost the Refrigerator

This appliance defrosts automatically and the water is channeled to the back toward the drain installed for this purpose (fig. 5). Here, the heat produced by the compressor will make it evaporate. The only thing you must do is to periodically check and clean the hole of the drain, which is located behind the vegetable crispers, so that the water drains properly.

How to Defrost the Freezer

- Every so often, remove the frost with the scraper provided with the appliance (do not use knives or metal objects).
- If the frost is more than 15 mm thick, the freezer must be defrosted.

Proceed as follows: turn the thermostat knob (A) to the setting ●. Then wrap all the frozen and fast-frozen food in newspaper, placing it either in the refrigerator or in a cool place. Leave the freezer door open so that the frost thaws completely. You can speed this process by placing containers of warm water in the compartment.

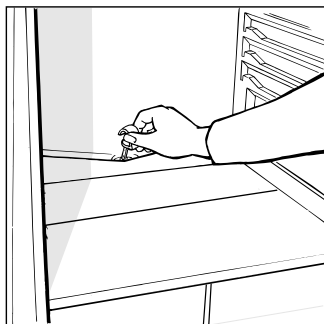

Fig. 5

Cleaning and maintenance

Always unplug the appliance from the mains before cleaning.

- Your appliance is manufactured with hygienic odourless materials. To preserve these characteristics, always use sealed containers for strong smelling foods to avoid the formation of odours that are difficult to remove.

- Use only a water and bicarbonate solution: Clean the internal and exterior of your appliance with a sponge soaked with a warm water and sodium bicarbonate solution, which is also a good disinfectant. If you do not have any sodium bicarbonate at home, use neutral detergent.

- What not to use: Do not use abrasive detergents, bleach or detergents containing ammonia. Never use solvent based products.

- Dishwashable: All the removable parts can be cleaned by soaking in hot soapy water or detergent. If you own a dishwasher, you may wash these parts in the dishwasher. Remember to dry thoroughly before replacing them.

- What about the back panel? Dust may deposit on the back panel and affect the proper running of the appliance. To remove dust, vacuum away the dust very carefully using the appropriate vacuum cleaner accessory.

- Discontinued use of the appliance: If the appliance is not in use for any length of time, remember to clean the interior and dry thoroughly, leaving the doors open to prevent the formation of bad odours and mould.

- How to replace the internal lamp. The lamp for the internal light is situated at the rear of the thermostat box. To replace it, disconnect the appliance from the electricity mains, unscrew the faulty lamp and replace it with a new one featuring a wattage no higher than that indicated on the protection (15 W or 25 W), as illustrated in figure 6.

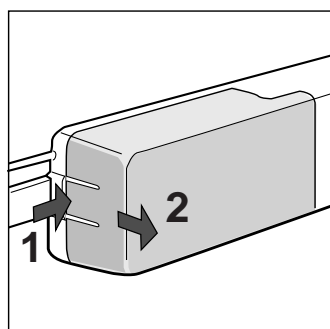

Fig. 6

Is There a Problem?

The refrigerator does not function.

Have you checked whether:

- The main switch for the electricity to the apartment or home has been turned off;
- The plug is properly inserted in the outlet;
- The outlet is adequate; try inserting the plug into another outlet in the room.

The refrigerator and the freezer do not cool properly.

Have you checked whether:

- The doors do not close well or the seals are faulty;
- The doors are left open too long;
- The thermostat knob is not on the proper setting;
- The refrigerator or freezer is overfilled.

The food in the refrigerator becomes too cold.

Have you checked whether:

- The thermostat knob is on the proper setting;
- The food is in contact with the back wall - which is the coldest part.

The motor runs continuously.

Have you checked whether

- The doors are not closed well or have remained open too long;
- The ambient temperature is too high;
- The thermostat knob is not on the proper setting.

The appliance makes too much noise.

The gas refrigerant produces a slight noise even when the compressor is not running (this is not a defect).

Have you checked whether:

- The refrigerator is level.
- The appliance was installed between cabinets or objects that vibrate and make noise.

There is water on the bottom of the refrigerator.

Have you checked whether:

- The hole for draining the water from the frost is clogged (see fig. 5).

If after all the checks, the appliance still does not operate or the problem persists, call the nearest Service Centre and inform them of: the type of problem, the abbreviation of the model name (Mod.) and the relative numbers (S/N) written on the rating plate located at the bottom left next to the vegetable crisper (see examples in the figures below).

Mod. RG 2330		TI	Cod. 93139180000	S/N 704211801	
220 - 240 V-	50 Hz	150 W	70 W	Fuse	Max 15
Total	340	75		Freez. Capac	Class
Gross Bruto		Gross Bruto	Net Util Utile	Gross Bruto	Poder de Cong
					kg/24 h 4,0
Compr. Syst.	R 134 a	Test Pressure	HIGH-235		Clase N
Kompr.	kg 0,090	P.S.-I.	LOW 140		Classe
Made in Italy 13918					

Never call on unauthorized technicians and always refuse spare parts which are not originals.



Reversing the door opening

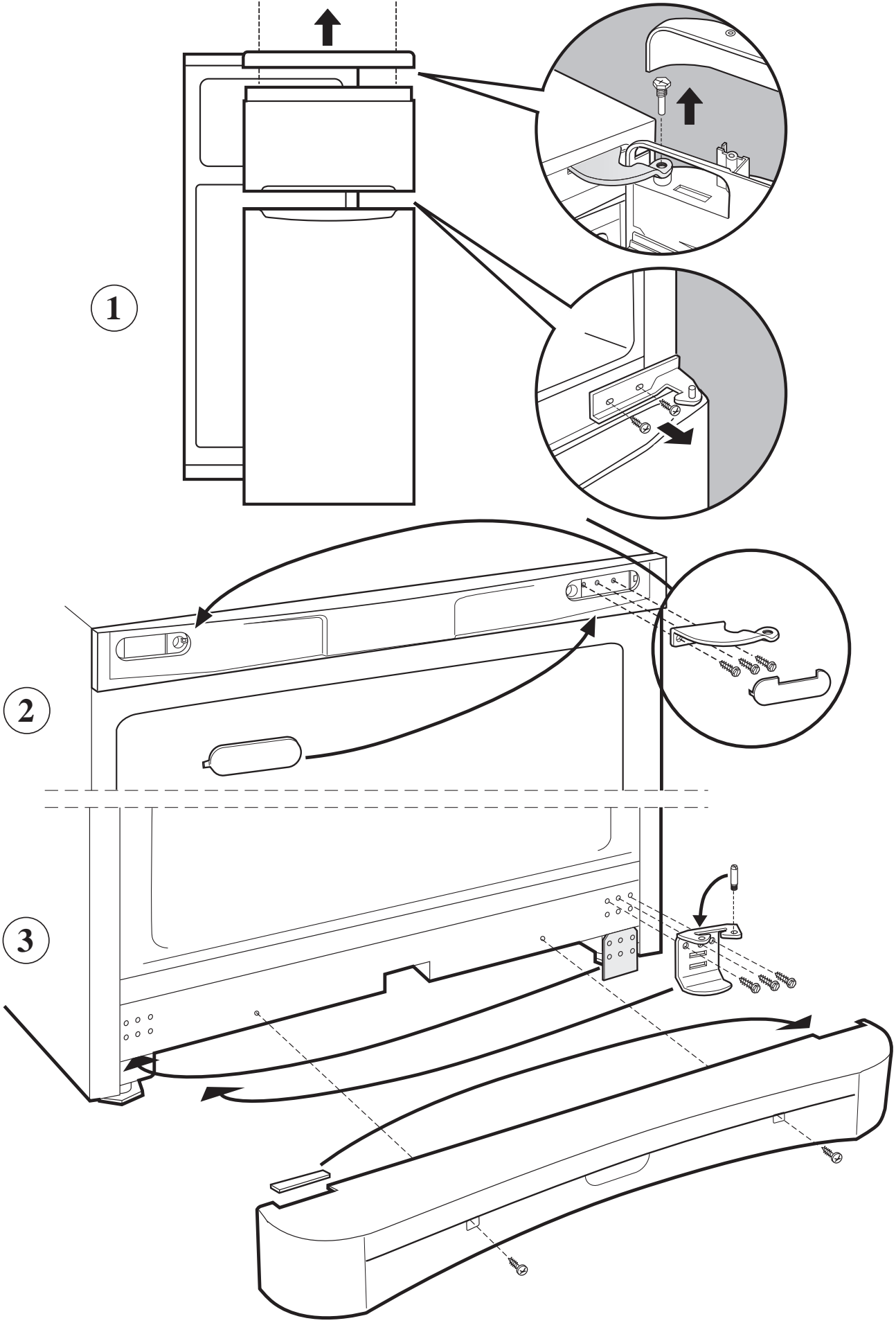

4

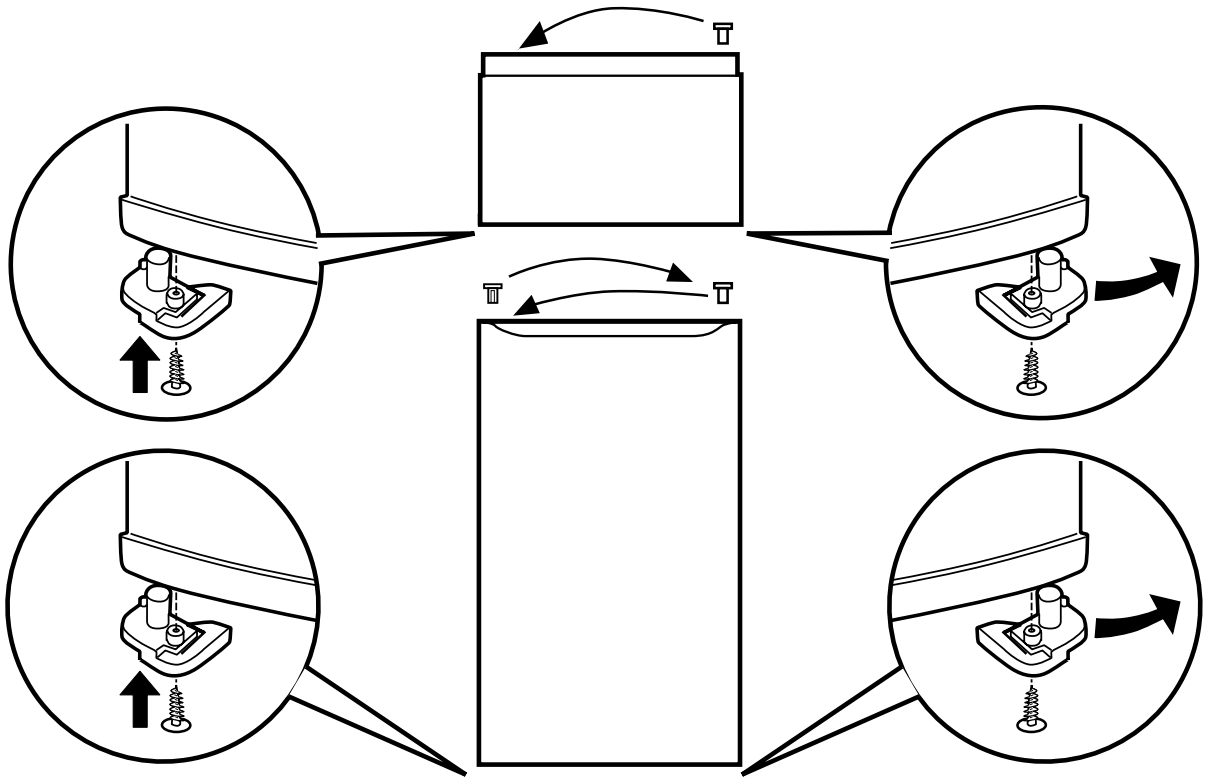

5

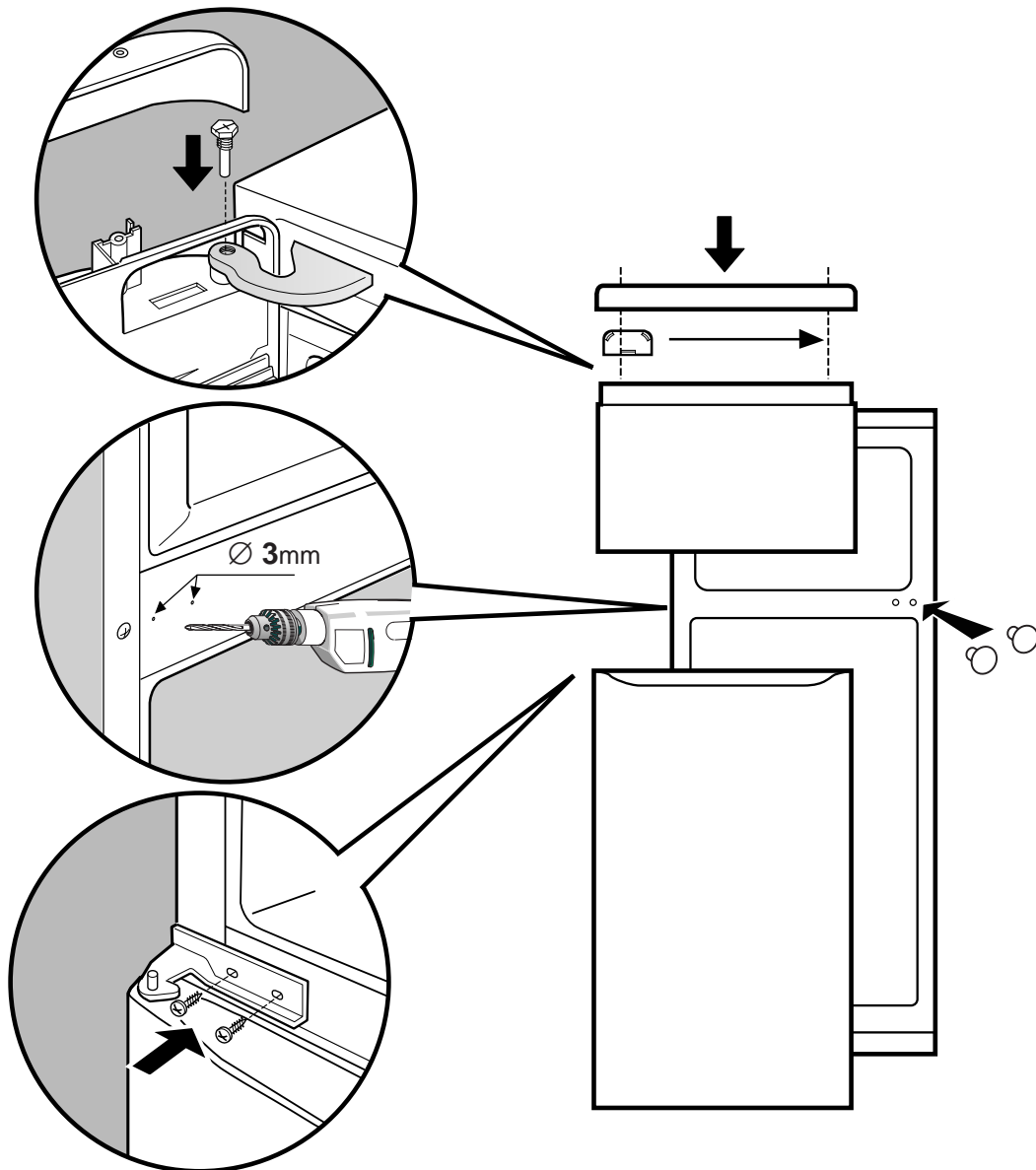

Merloni Elettrodomestici

Viale Aristide Merloni 47

60044 Fabriano

Italy

Tel +39 0732 6611

Fax +39 0732 662501

www.merloni.com